

## 1535nm Eyesafe Laser Rangefinder Module 1525C

Model:LRF1525C



### DESCRIPTION

The ERDI LASER® LRF1525C laser rangefinder boasts an eyesafe, compact design, lightweight construction, lower power consumption, extended lifespan, and a wide temperature range. Widely applied in tasks such as reconnaissance, surveying, and mapping, this laser rangefinder module comes without a shell but offers a diverse array of interfaces for seamless integration into various systems. Users can enjoy the convenience of PC software and communication protocols, enhancing usability for handheld devices and multifunctional systems.

### FEATURES

- Single shot ranging and continuous ranging
- 3-target detection, front and back target indication
- Contain self-checking function
- Wake-on-lan function
- Number of emitted pulses during MNBFB  $\geq 1 \times 10^6$ times

### APPLICATIONS

- Handheld devices
- Unmanned aerial vehicle
- Electro-optical pod
- Border surveillance

### PERFORMANCE

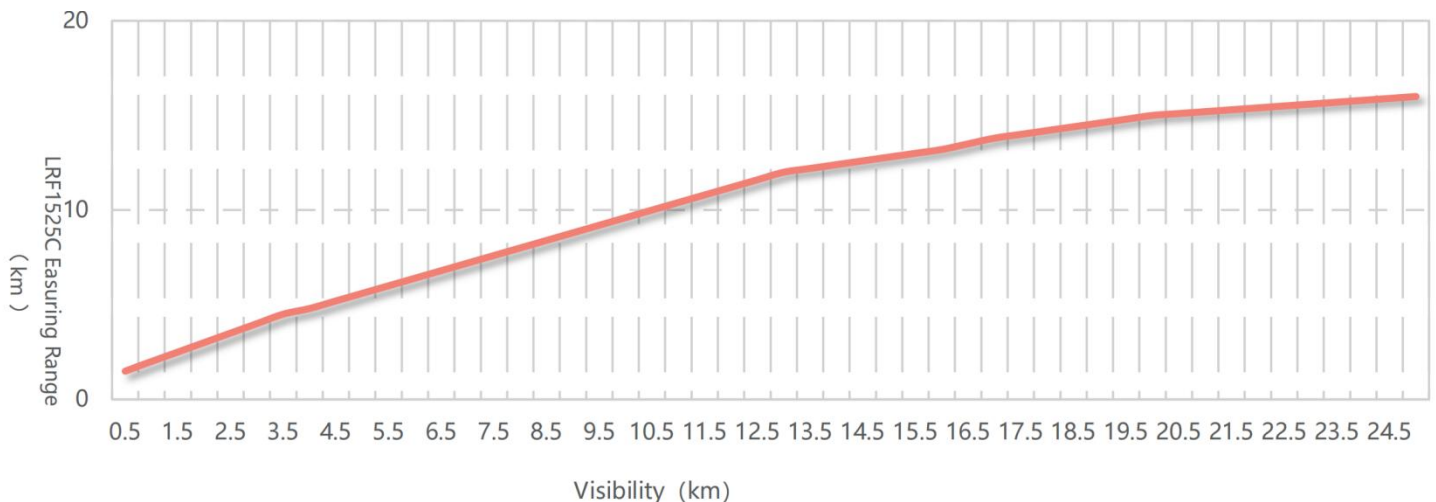

## ERDI SPECIFICATIONS

Parameters	Unit	Argument	Comments
Safety Class	-	Class 1	Eyesafe
Wavelength	nm	1535±5	-
Ranging Capability	m	≥6000	Target of 0.5m × 1.7m visibility of 6km
		≥15000	Target of 3m × 3m visibility of 20km
		≥25000	Target of 4m × 6m of 30km
Min Measuring Range	m	≤50	
Range Accuracy	m	≤±2	Affected by weather conditions and target reflectivity
Measuring Rate	Hz	0.5~10	-
Multiple Targets	-	5	-
Precision	%	≥98	-
False Alarm Rate	%	≤1	Probability of occurrence of noise
Dimensions	mm	125×85×58.5	L×W×H
Weight	g	≤400	-
Data Interface	-	molex-532610771	Other interfaces can be customized
Power Supply	v	12	-
Peak Power Consumption	w	3	Max power consumption when start up
Standby Power Consumption	w	1.2	Function to be shut down by external signal can be customized
Vibration	-	5Hz, 2.5g	-
Shock	-	Axial 100g, 1ms	Can be increased based on user's application scenarios
Operation Temperature	°C	-40~+65	-
Storage Temperature	°C	-55~+70	-

## ERDI STRUCTURAL DRAWING (In mm)

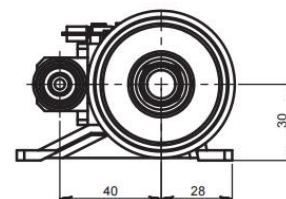
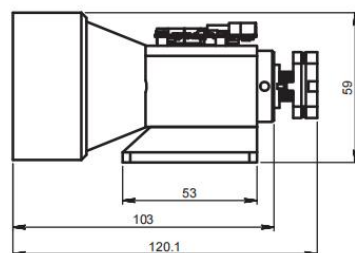
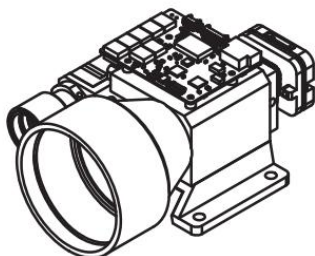
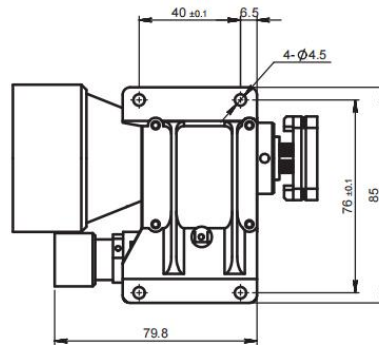

## ERDI ELECTRICAL INTERFACE

Electrical connector model: J30J; Detailed definition of electrical interface is shown in the following table:

Table 1 Interface definition

Pin serial number	definition	function	Remarks:
1	GND		
2	GND		
3	GND		
4	VCC 12V		
5	VCC 12V		
6	RS422 RX+		
7	RS422 RX-		
8	RS422 TX-		
9	RS422 TX+		

## ERDI COMMUNICATION PROTOCOL

The data transmission between the distance measuring machine and the upper computer includes the following contents:

**Control command:** including start ranging, continuous ranging, single ranging, query command, etc.

**Returned data:** including distance information, ambient temperature, ZRT status, etc. The 422 bus is used for data exchange between the distance measuring machine and the upper computer. Specific software communication protocols are as follows:

**Communication format: RS422 communication, baud rate: 115200bps;**

Data format: 8 bit data, one start bit, one stop bit, without parity check. The data consists of header byte, command part, data length, parameter part and check byte.

Communication mode: master-slave communication mode is adopted for the master control and the distance measuring machine. The master control sends control command to the distance measuring machine, and the distance measuring machine receives and executes the command. In the ranging state, the distance measuring machine returns the data and state of the distance measuring machine to the upper computer according to the ranging period. The communication format and command contents are shown in the following table.

Master control sending

The sending message format is as follows:

STX0	CMD (CMD)	LEN:	DATA1H :	DATA1L :	CHK (CHK)
------	--------------	------	-------------	-------------	--------------

Table 2 Format of sending message

S/N	name	explain	code	Remarks
1	STX0	Message start mark	H)	
2	CMD (CMD)	Command word	See Table 3	
3	LEN:	Data length	Number of all bytes except start flag, command word and check	
4	DATAH (DATAH)	parameter		
5	DATAL (DATAL)			

S/N	name	explain	code	Remarks
6	CHK (CHK)	Exclusive or check	Byte exclusive or	

Table 3 Instructions on commands and data words sent by the master controller to the ZRT

S/N	Command word	function	Data byte	Remarks:	length	Example Code
1	0x00	Standby (continuous ranging stop)	DATAH=00 (H) DATAL=00 (H)	Distance measuring machine stops working	6Bytes	55 00 02 00 00 57
2	0x01	Single range measurement	DATAH=00 (H) DATAL=00 (H)		6Bytes	55 01 02 00 00 56
3	0x02	Continuous range measurement	DATAH=XX (H) DATAL=YY (H)	DATA represents the ranging period in ms	6Bytes	55 02 02 03 E8 BE (1Hz)
4	0x03	Self-inspection	DATAH=00 (H) DATAL=00 (H)		6Bytes	55 03 02 00 00 54
5	0x11	APD power on	DATAH=00 (H) DATAL=00 (H)		6Bytes	55 11 02 00 00 46
6	0x12	APD power off	DATAH=00 (H) DATAL=00 (H)		6Bytes	55 12 02 00 00 45

a) Master control receiving format

The format of the received message is as follows:

STX0	CMD (CMD)	LEN:	DATA <sub>n</sub> (DATA <sub>n</sub> )	DATA0	CHK (CHK)
------	-----------	------	--	-------	-----------

Table 4 Format of received message

S/N	name	explain	code	Remarks:
1	STX0	Message start mark 1	H)	
2	CMD (CMD)_ JG: JG	Data command word	See Table 5	
3	LEN:	Data length	Number of all bytes except start flag, command word and check	
4	D <sub>n</sub> : D <sub>n</sub>	parameter	See Table 5	
5	D0			
6	CHK (CHK)	Exclusive or check	Byte exclusive or	

Description of master control receiving status:

Table 5 Description of data word sent by the ranging machine to the master control

S/N	Command word	function	Data byte	Remarks	Total length
1	0x00	Standby (continuous ranging stop)	D1=00 (H) D0=00 (H)		6Bytes
2	0x03	Self-inspection	D7~D0	D0: char type, representing APD temperature in degrees Celsius; D1: APD high pressure value (unit: V); D3-D2: dead zone value (unit: 1m) D5-D4: - 5V voltage in 0.01V. D7-D6:+5V voltage in 0.01V	12Byte
3	0x11	APD power on	DATAH=00 (H) DATAL=00 (H)		6Bytes

S/N	Command word	function	Data byte	Remarks	Total length
4	0x12	APD power off	DATAH=00 (H) DATAL=00 (H)		6Bytes
5	0xED (x ED)	Working overtime	0x00 0x00	Laser is under laser protection and cannot be measured.	6Bytes
6	0xEE:	Verification error (of a test)	0x00 0x00		6Bytes
7	0x01	Single range measurement	D9 D8 D7 D6 D5 D4 D3 D2 D1 D0	D8-D6 First target distance (unit: 0.1m) D5-D3 Second target distance (0 for single target) (unit: 0.1m) D2-D0 Distance of the third target (0 for single target) (unit: 0.1m) Target from near to far D9 (bit7-bit0) flag byte: D9 bit7 represents main wave; 1: With main wave, 0: without main wave. D9 bit6 represents echo; 1: With echo, 0: No echo D9 bit5 represents laser state; 1: Laser OK, 0: Laser fault D9 bit4 timeout alarm, 1 normal, 0 timeout D9 bit3 invalid,=1 D9 bit2 represents APD status; 1: Normal, 0: Error D9 bit1 indicates whether there is front target; 1: With target, 0: No target (the target before the primary target is the previous target). D9 bit0 indicates whether there is a rear target; 1: With target, 0: No target (the target after the primary target is the rear target)	14Bytes
8	0x02	Continuous range measurement	D9 D8 D7 D6 D5 D4 D3 D2 D1 D0	D8-D6 First target distance (unit: 0.1m) D5-D3 Second target distance (0 for single target) (unit: 0.1m) D2-D0 Distance of the third target (0 for single target) (unit: 0.1m) Target from near to far D9 (bit7-bit0) flag byte: D9 bit7 represents main wave; 1: With main wave, 0: without main wave. D9 bit6 represents echo; 1: With echo, 0: No echo D9 bit5 represents laser state; 1: Laser OK, 0: Laser fault D9 bit4 timeout alarm, 1 normal, 0 timeout D9 bit3 invalid,=1 D9 bit 2 represents APD status; 1: Normal, 0: Error D9 bit1 indicates whether there is front target; 1: With target, 0: No target (the target before the primary target is the previous target). D9 bit0 indicates whether there is a rear target; 1: With target, 0: No target (the target after the primary target is the rear target)	14Bytes

S/N	Command word	function	Data byte	Remarks	Total length
				target)	
Remarks: ① Data byte/bit is not defined, default is 0;					

## INSTRUCTIONS FOR USING SOFTWARE

### 1 Connect the serial port

Set up the serial port as shown in Figure 1, click“Open”.

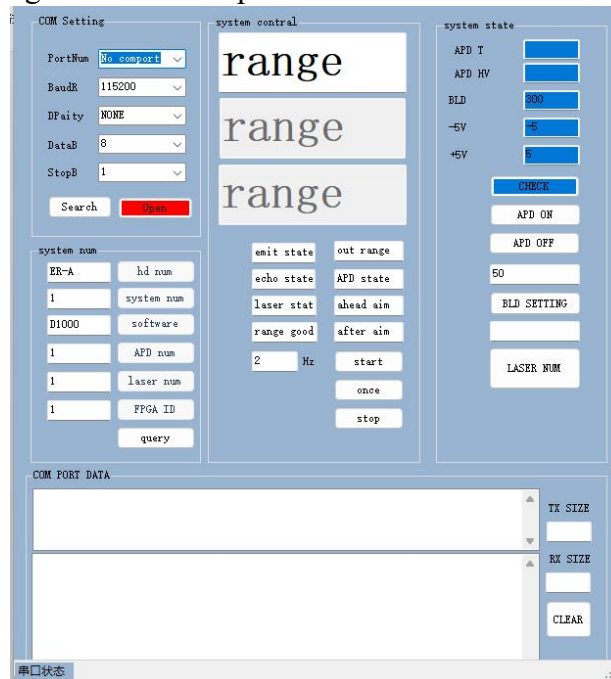

Figure 1 Serial port connection

### 2 Self-test

Click“CHECK” ,Start the product self-test, This is shown in Figure 2。 The display value of  $\pm 5V$  is /100 is the current voltage value, and the nearest gate is 50, which means that the distance within 50m is masked. APD temperature and high voltage are the current state values inside the product, and the values are  $^{\circ}C$  and V. You can enter the distance you want to block in the Closest Distance Gating input box, and then click the "BLD SETTING" button to set the distance to be blocked.

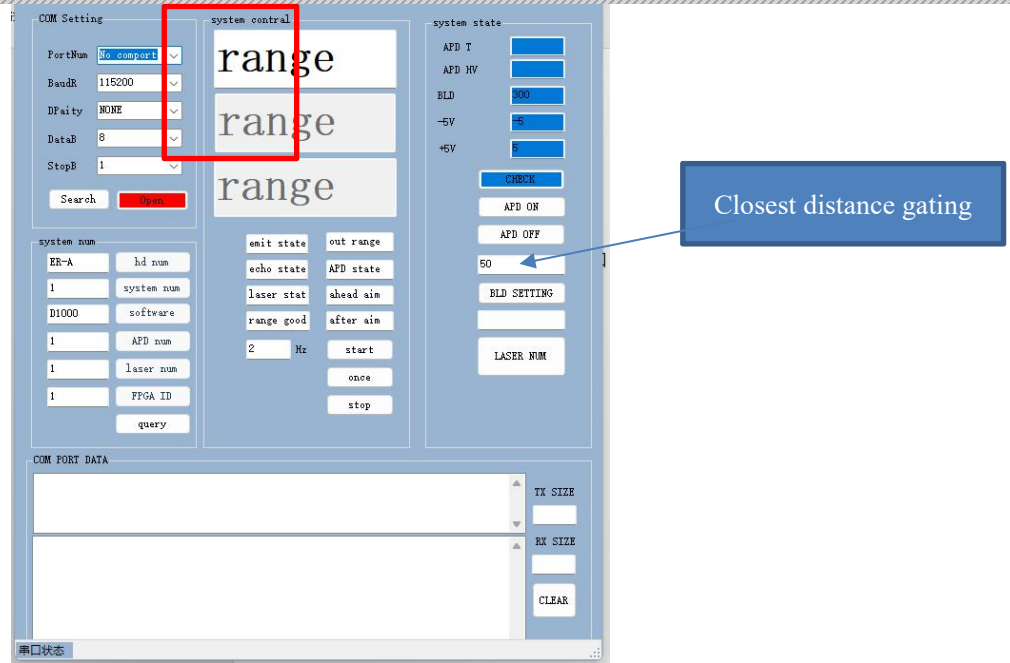

Figure 2 Self-test

### 3 Start ranging / Single ranging

Enter the radiation frequency in the “Hz” box on the left.

Click the "start" button to start the product ranging and click the "stop" button to stop the ranging, as shown in Figure 3. The "once" button is clicked Single ranging, the product radiates once, a ranging measurement is completed, and the distance is displayed.

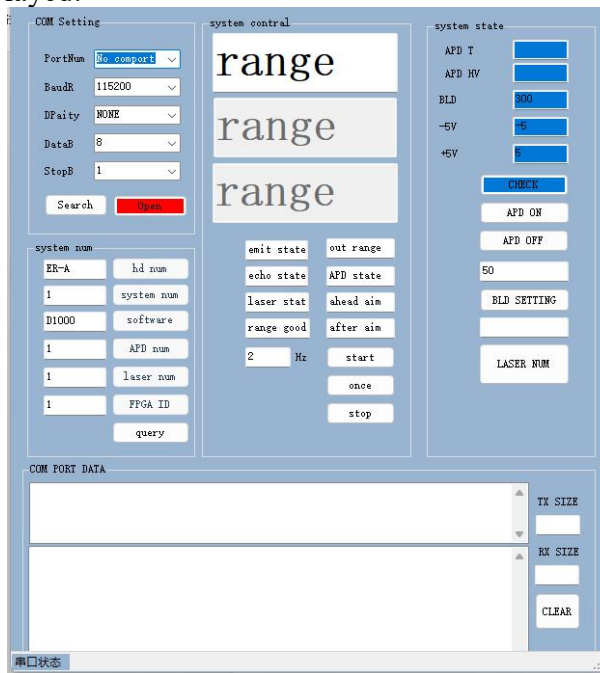

Figure 3 Ranging begins

